



ZEPHYR LOCK

Innovative locking solutions for the locker industry

30 Pecks Lane
Newtown, CT 06470
Toll Free: 866-937-4971
Fax: 203-778-1016
Email: info@zephyrlock.com
Web: www.zephyrlock.com

Electronic RFID Locker Locks



2254 (front view)



2154 - 2254 (rear view)

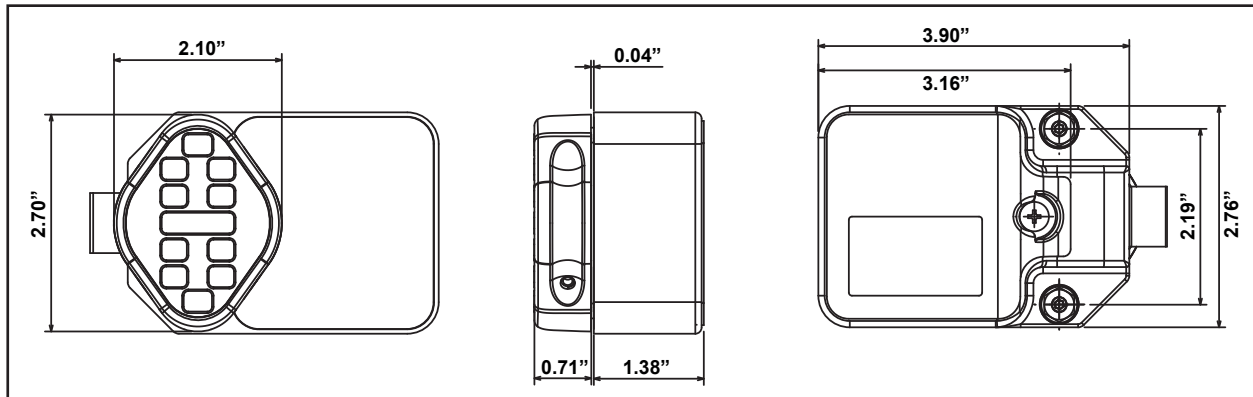

FEATURES

- Card key with same security level as used in Banking Smart Cards; 2254/55 has keypad for additional access
- Complies with all ADA guidelines for ADA accessibility
- Engineered to work on all standard metal single point, box locker, gravity latch/multipoint lockers, wood & laminate lockers and casework
- Supervisory override card capability
- Programmable for both day use and permanent use
- Custom programmability available
- High impact polycarbonate housing
- Ability to track user history
- New user cards available in the event card is lost
- Battery Powered; Requires (4) AA batteries offering life cycle of 10,000 - 20,000 uses depending on model
- Electronic RFID locks have a 1 year warranty from time of shipment

APPLICATIONS

- Athletic, student & swimming facility lockers
- OEM equipment
- Health & fitness clubs, day spas, wellness centers
- Employee lockers
- Golf & country clubs, hotels, resort lockers
- Evidence lockers
- Models 2154 & 2254 made for right hinged doors; Models 2155 & 2255 are for left hinged doors



Model 2154 shown installed on wood door